

6

5

4

3

2

1

D

C

B

A

D

C

B

A

| REVISION RECORD |         |           |       |
|-----------------|---------|-----------|-------|
| LTR             | ECO NO: | APPROVED: | DATE: |
|                 |         |           |       |
|                 |         |           |       |
|                 |         |           |       |
|                 |         |           |       |

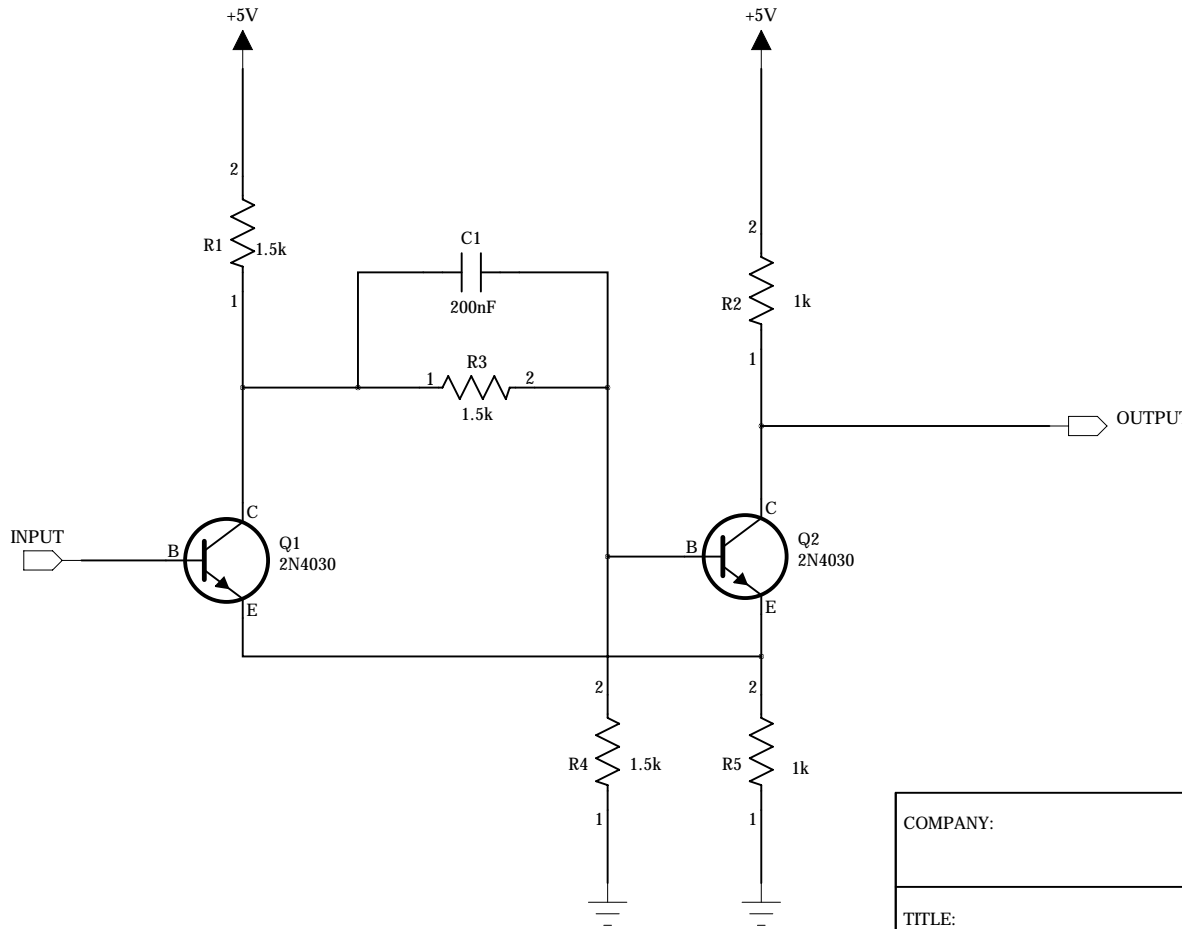

|                |  |       |  |                  |  |            |  |
|----------------|--|-------|--|------------------|--|------------|--|
| COMPANY:       |  |       |  | <Company Name>   |  |            |  |
| TITLE:         |  |       |  | <Title>          |  |            |  |
| CODE:          |  | SIZE: |  | DRAWING NO:      |  | REV:       |  |
| <Code>         |  | A4    |  | <Drawing Number> |  | <Revision> |  |
| SCALE: <Scale> |  |       |  | SHEET: bf 1      |  |            |  |

|                  |                |
|------------------|----------------|
| DRAWN:           | DATED:         |
| <Drawn By>       | <Drawn Date>   |
| CHECKED:         | DATED:         |
| <Checked By>     | <Checked Date> |
| QUALITY CONTROL: | DATED:         |
| <QC By>          | <QC Date>      |
| RELEASED:        | DATED:         |
| <Released By>    | <Release Date> |