

6

5

4

3

2

1

D

C

B

A

D

C

B

A

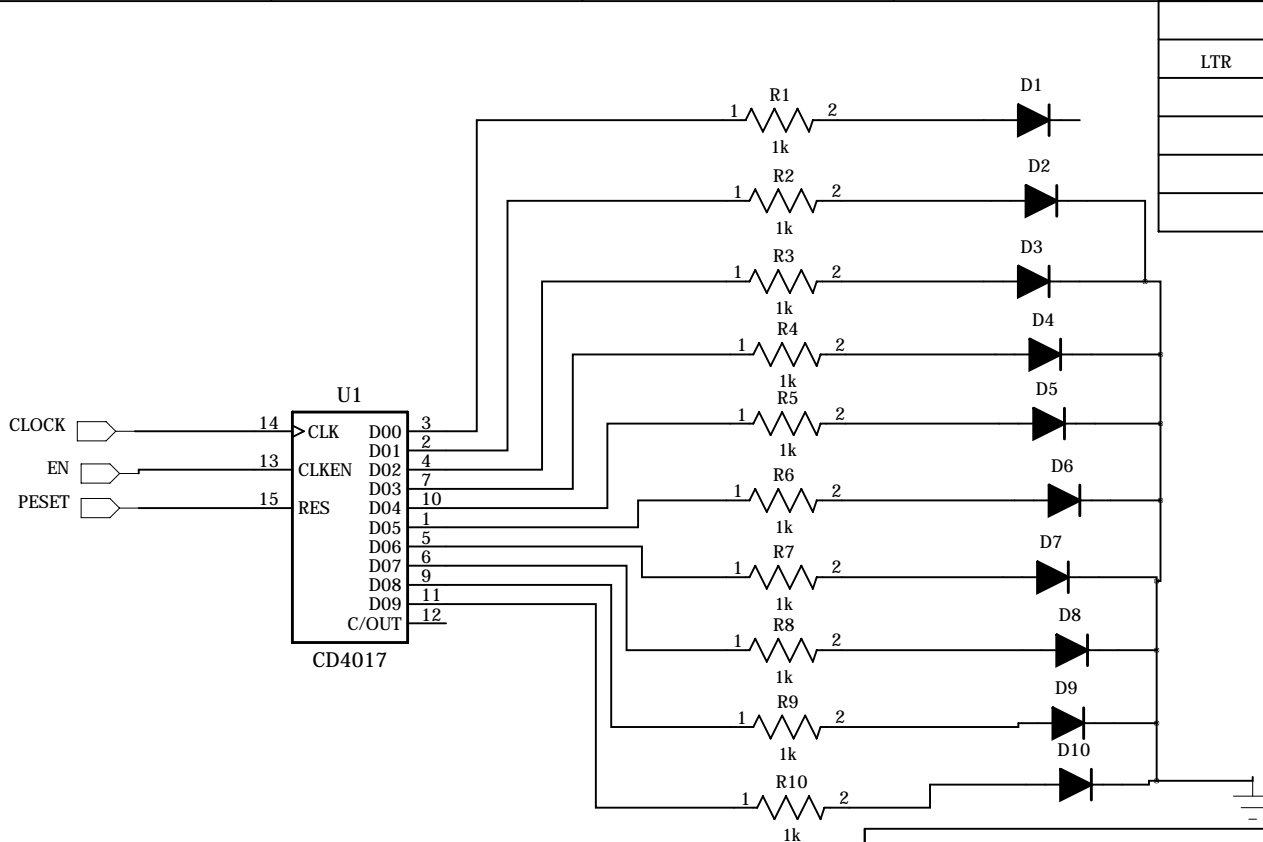

REVISION RECORD			
LTR	ECO NO:	APPROVED:	DATE:

COMPANY: <Company Name>

TITLE: <Title>

DRAWN: <Drawn By>	DATED: <Drawn Date>	CODE: <Code>	SIZE: A4	DRAWING NO: <Drawing Number>	REV: <Revision>
CHECKED: <Checked By>	DATED: <Checked Date>	SCALE: <Scale>			
QUALITY CONTROL: <QC By>	DATED: <QC Date>	SHEET: 1 OF 1			
RELEASED: <Released By>	DATED: <Release Date>				